



Main

Range of product	Telemecanique Inductive proximity sensors XS
Series name	Application
Product or component type	Sensor
Sensor type	Inductive proximity sensor
Device application	Rotation monitoring
Sensor name	XSA
Sensor design	Cylindrical M30
Size	81 mm
Body type	Fixed
Detector flush mounting acceptance	Flush mountable
Material	Metal
Enclosure material	Nickel plated brass
Type of output signal	Discrete
Wiring technique	3-wire
[Sn] nominal sensing distance	10 mm
Discrete output function	1 NC
Output circuit type	DC
Discrete output type	PNP
Electrical connection	Cable
Cable length	2 m
[Us] rated supply voltage	12...48 V DC with reverse polarity protection
Switching capacity in mA	<= 200 mA with overload and short-circuit protection
IP degree of protection	IP67 conforming to IEC 60529

Complementary

Thread type	M30 x 1.5
-------------	-----------

Detection face	Frontal
Front material	PPS
Sensing range	> 8...15 mm
Adjustable frequency range	6...150 cyc/mn
Operating zone	0...8 mm
Differential travel	3...15% of Fr
Repeat accuracy	3% of Sr
Cable composition	3 x 0.34 mm ²
Wire insulation material	PvR
Status LED	Output state: 1 LED (red)
Supply voltage limits	10...58 V DC
Switching frequency	<= 100 Hz
Maximum voltage drop	<1.8 V (closed)
Current consumption	0...15 mA no-load
Run-up delay at power-up	9 s standard
Marking	CE
Threaded length	67 mm
Length	81 mm
Net weight	0.3 kg

Environment

Product certifications	CSA UL CCC
Ambient air temperature for operation	-25...70 °C
Ambient air temperature for storage	-40...85 °C

Packing Units

Unit Type of Package 1	PCE
Number of Units in Package 1	1
Package 1 Weight	230 g
Package 1 Height	4.1 cm
Package 1 width	9.5 cm
Package 1 Length	13.2 cm
Unit Type of Package 2	S02
Number of Units in Package 2	22
Package 2 Weight	5.35 kg
Package 2 Height	15 cm
Package 2 width	30 cm
Package 2 Length	40 cm

Offer Sustainability

Sustainable offer status	Green Premium product
REACH Regulation	REACH Declaration
EU RoHS Directive	Pro-active compliance (Product out of EU RoHS legal scope) EU RoHS Declaration
Mercury free	Yes
RoHS exemption information	Yes
Environmental Disclosure	Product Environmental Profile
Circularity Profile	End of Life Information

Contractual warranty

Warranty	12 months
----------	-----------

Dimensions

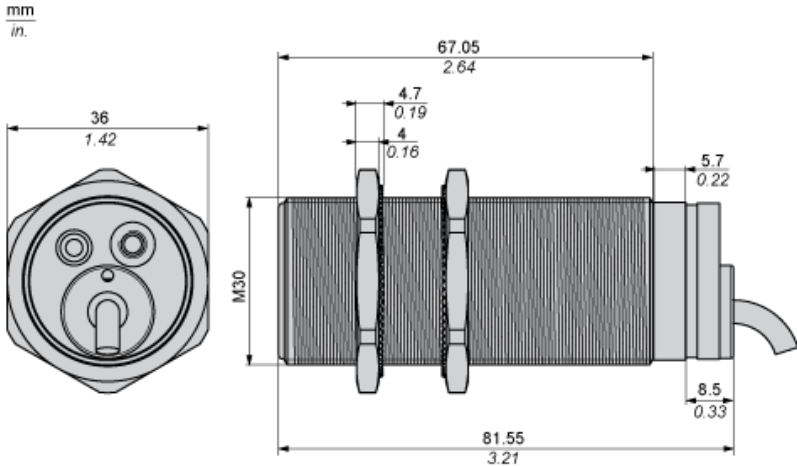

(1) LED

Minimum Mounting Distances

Side by side

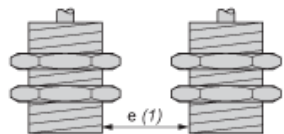

$e (1) \geq 20 \text{ mm}/0.79 \text{ in}$

Face to face



$e (2) \geq 120 \text{ mm}/4.72 \text{ in}$

Facing a metal object



$e (3) \geq 30 \text{ mm}/1.18 \text{ in}$.

Wiring Schemes

3-wire DC

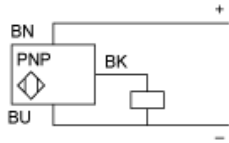

- BU : Blue
- BN : Brown
- BK : Black

Performance Curves

Standard Steel Target : 30x30x1 mm



- (1) Pick-up points
- (2) Drop-out points (object approaching from the side)
- (y) Sensing distance in mm